

GAS-CO-300-X Carbon Monoxide Gas Sensor Transmitter With Analog Output

4-20 mA (0-300 ppm), with enhanced gas radical sensing for Very Early Fire and Smoke Detection.

Product Summary:

The exchangeable sensor transmitter cartridge is used for continuous monitoring of the ambient air to detect the presence of Carbon Monoxide (CO) concentrations in the range of 0-300ppm along with CO gas radicals for Very Early Fire and Smoke Detection, in accordance with the defined specifications.

The product's standard linear 4-20mA analogue output may be connected to the Gas Alarm range of standalone and multi-channel gas controllers, or to any PLC, SCADA or DCS system for live monitoring, alarm generation, HVAC control or process parameter control.



Key Product Features:

- Fully sealed sensor cell with gas-specific gel electrolyte and hydrophobic filter.
- High accuracy, selectivity and reliability with low calibration drift over time.
- Long operational lifespan compared to solid state semiconductor sensors.
- Simplified maintenance via exchange of pre-calibrated sensor cartridges or easy on-site calibration.
- Power supply input is diode-protected against reverse voltage with anti-poisoning and over-flooding protection.
- Fast tool-free wire termination via the supplied terminal block.
- Supplied with shipping cap to protect sensor during transport .
- Various housing options available (IP44, IP65/NEMA 4X), duct mounting kit also available.



GAS-CO-300-D

Typical Industries and Applications:

Carbon Monoxide is a colourless, odourless and highly toxic gas which is known as “the silent killer”. As such, the GAS-CO-300-X offers major benefits for personnel safety and asset protection in such applications as:

- Mining, materials handling and processing plants (e.g. spontaneous combustion and Very Early Fire and Smoke Detection monitoring in coal mines and related facilities).
- Parking garages, tunnels, emergency shelters, loading docks and engine maintenance/test stations (e.g. CO monitoring for safety, ventilation fan control for energy and greenhouse emission savings).
- Heavy industry e.g. power generation, petrochemical processing, production facilities, laboratories.
- Many other applications where CO concentration must be monitored within strict limits.

Technical Specification: (Subject to change under continuous improvement program)

Electrical	
Power supply	+16 - 29 VDC with reverse polarity diode protection
Power consumption	22mA max. (0.5VA @ +24VDC)
Analog signal output	Linear proportional 4-20mA current loop
Output load	≤ 500 Ω for current signal
Sensor Performance	
Sensor element type	Electrochemical
Detected gas	Carbon Monoxide (CO)
Measurement range	0-300 ppm
Accuracy	±3 ppm
Resolution	0.5 ppm
Repeatability	< ±5% FS
t90 Time	≤ 50 seconds (response time ≤ 30 seconds)
Zero-point variation	±4 ppm
Zero/Gain calibration drift	< ±0.4% FS signal per month
Sensor Life Time	>6 years (with recommended calibration interval)
Recommended calibration interval	12 months

Environmental and Physical Specifications:

Storage time	6 months @ 5 – 30 °C
Operating temperature range	-15 °C to +50 °C
Humidity range	10-95% RH (non-condensing)
Pressure range	Atmospheric ±20%
Wiring	2 Wire
Wire Connection	Spring loaded terminal min 0.25 mm ² to max 2.5 mm ²
Mounting	Wall mounting
Relative Gas Density	0.97 (Air=1)
Mounting Height	1.5 m to 1.8 m
Recommended Coverage Area	465 m ² to 930 m ² , ideal condition assumed
Dimensions (sensor cartridge only)	38 mm (L) x M25 mounting diameter
Weight (sensor cartridge only)	30 g
Sensor Cartridge	Polycarbonate IP65
Optional Housings Specifications:	F: ABS, IP44, UL 94: V0, weight: 0.1 Kg D: Polycarbonate, IP65, UL 94: V2, weight: 0.15 Kg K: D Housing with Duct Kit, weight: 0.1 Kg

Standards and Approval Compliance:

- EMC Directives 2014/30/EU
- CE
- IP 65/66 (EN 60529/ DIN VDE – 0470-1)
- Impact Resistant IK08 (DIN EN5012/VDE 0470 segment 100)
- UL508 & CSA C22.2 No. 14-13 Certified Enclosure for Industrial Control Equipment
- UL50 & CSA 22.2 No. 94.1-07 Certified Enclosure for Electrical Equipment

Product Selection:

- GAS-CO-300-F (IP44)
- GAS-CO-300-D (IP65)
- GAS-CO-300-K (Duct)

Wiring Connection:

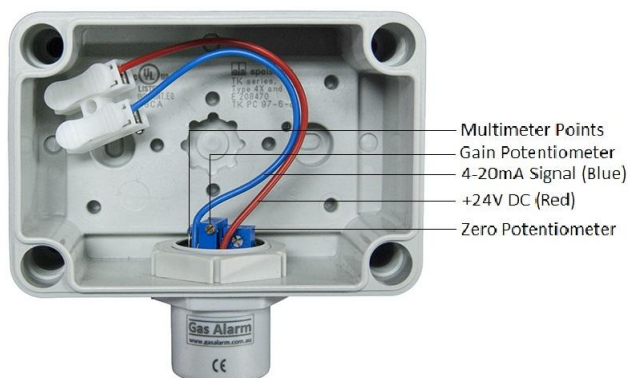

Note: GAS-CO-300-D (IP65 Housing): Tough, rugged, glass-fibre reinforced, heavy duty polycarbonate industrial housing with Polyurethane Sealing; Operating Temp: -25 to +70 Degree Celsius; Expected Life: 10 years in normal operating environment when serviced regularly; **Coverage Area:** 465 m² to 930m² "Ideal Conditions" assumed.

Product Dimensions (in mm): D Housing:

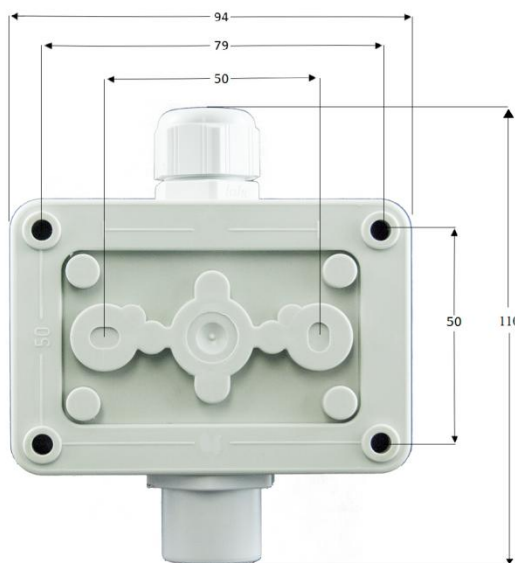

F Housing:

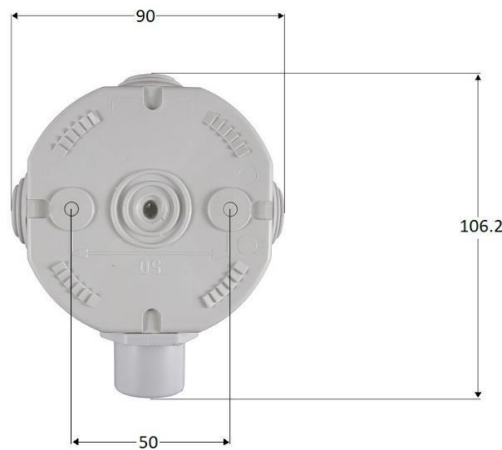

K Housing: (D housing with below duct kit)

